

**CRESTA  
FM1-25 RANGE  
SPRING ISOLATORS**

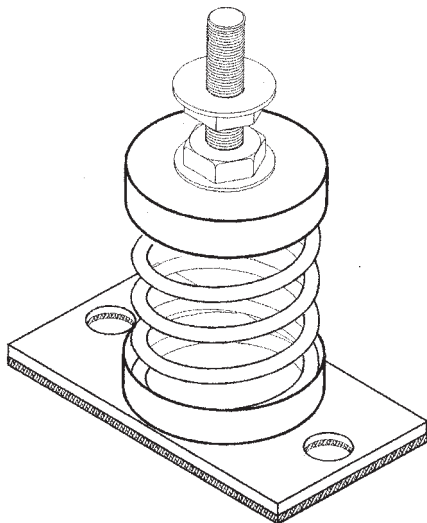

Isolator Reference	Spring Reference	Colour Code	Design rated load	Deflection at design load	Threaded
			kg	mm	
FM1-25	04	Red	40	25	M12
	06	Pink	60	25	M12
	10	White	100	25	M12
	14	Orange	140	25	M12
	19	Yellow	190	25	M12
	29	Green	290	25	M12
	40	Blue	400	25	M12
	46	Brown	460	25	M12
	57	Grey	575	25	M12
	75	Black	750	25	M12
	95	Purple	950	25	M12

The Cresta FM1-25 range of spring isolators incorporates the following design features:-

- Laterally stable helical steel springs.
- 25mm static deflection at design load.
- Minimum 50% overload capacity.
- A wide range of spring loads is available to suit most applications.
- High frequency base pad isolation.
- Levelling/height adjustment

Cresta sales staff can offer a selection service for spring isolators for most types of mechanical services plant and plant applications. Full plant details including total plant weight, running speed, type and nature of support structure and design requirements will be necessary to facilitate suitable spring isolator selection.

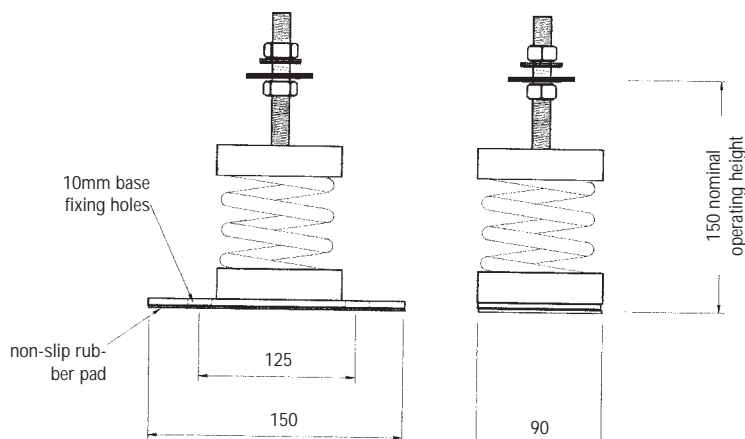

### CRESTA 25 SPRING RANGE LOAD DEFLECTION CHART

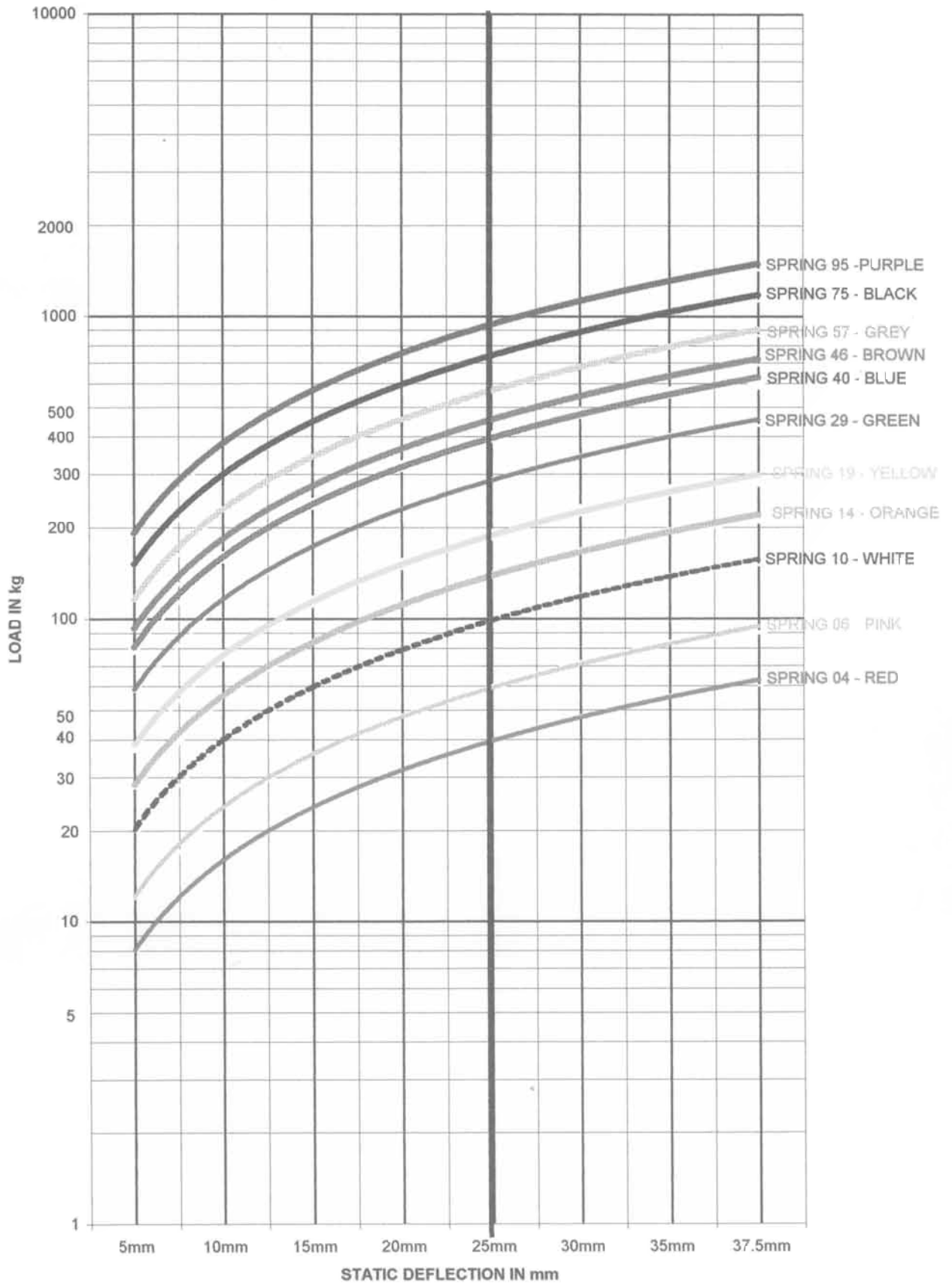

31